

## DV-5A Automatic Water Control Valve, Remote-Resetting, Pressure-Reducing Deluge Fire Protection Systems, 3–8 in. (DN80–DN200)

### IMPORTANT

Refer to Technical Data Sheet TFP2300 for warnings pertaining to regulatory and health information.

Scan the QR code or enter the URL in a web browser to access the most up-to-date electronic version of this document. Data rates may apply.



[docs.jci.com/tycofire/TFP1326](http://docs.jci.com/tycofire/TFP1326)



### General Description

The TYCO DV-5A Automatic Water Control Valves are diaphragm type valves that can be used in remote-resetting deluge fire protection systems. When properly trimmed, the DV-5A Valve with Remote-Resetting, Pressure-Reducing Trim can be opened and closed during a full-flow condition from a remote location. Key features are as follows:

- Pressure-Reducing function maintains pre-set outlet pressure.
- Remote-resetting feature provides the ability to reset the valve from one or more locations.
- Compact, space-saving design reduces valve room footprint and construction costs.
- Electric actuation is compatible with many types of automatic and manual release options.
- Actuation of fire alarms upon system operation is provided.

Available End Connections and Weights						
End Connection		Nominal Valve Size, ANSI Inches (DN)				
Inlet	Outlet	3 (80)	4 (100)	6 (150)	165,1 mm	8 (200)
		Weight, lb (kg)				
Thread	Thread	N/A	N/A	N/A	N/A	N/A
Groove	Groove	60 (27,2)	95 (43,1)	177 (80,3)	177 (80,3)	327 (148,3)
Flange	Groove	66 (30,0)	106 (48,1)	190 (86,2)	N/A	346 (157,0)
Flange	Flange	72 (32,7)	116 (52,6)	204 (92,5)	N/A	365 (165,6)

The DV-5A Valves are offered with the DV-5A Valve and separately ordered semi-assembled trim shown in Figure 6, or, for ease of installation, with the DV-5A Valve completely trimmed with or without a System Main Control Valve.

The diaphragm style design of the DV-5A Valve allows external resetting, providing for easy resetting of a deluge system without having to open a valve handhole cover to manually reposition a clapper and/or latch mechanism. Simply re-pressurizing the diaphragm chamber resets the valve.

Operation of the DV-5A Valve with Remote-Resetting, Pressure-Reducing

Trim is provided by an automatic electric detection system or remote manual electric activation. The easily installed trim configuration for the DV-5A Valve with Remote-Resetting, Pressure-Reducing Trim provides for emergency (manual) release of the valve at the valve location.

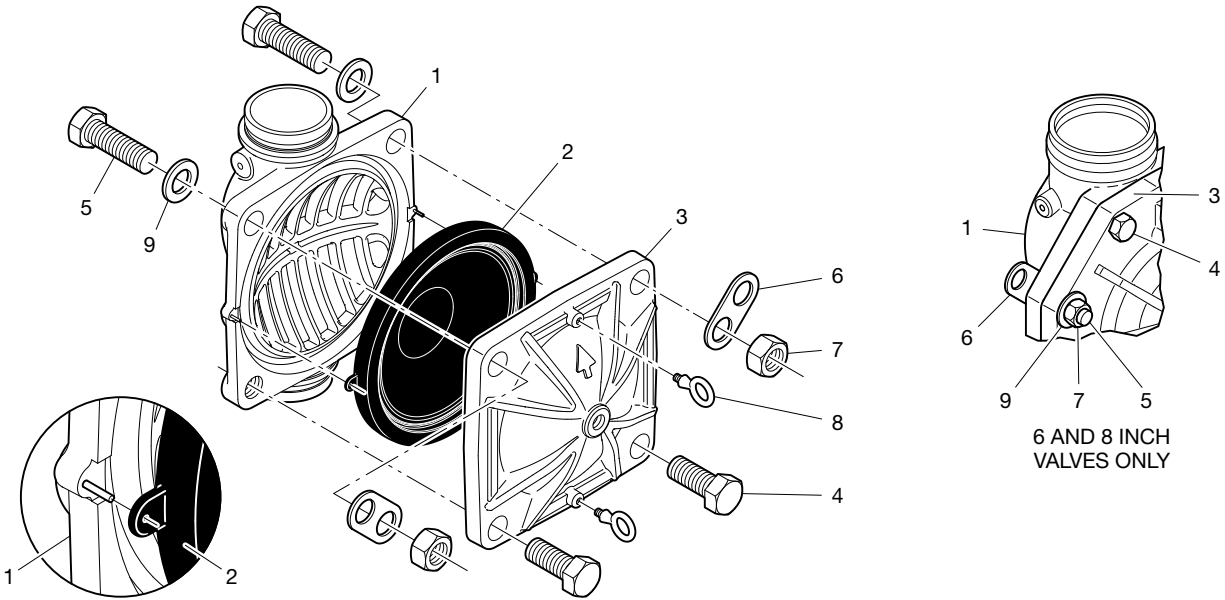
The DV-5A features internal and external coating of the valve to provide corrosion resistance. The external corrosion resistance of the epoxy coating permits the use of the DV-5A in corrosive atmospheres associated with many types of industrial processing plants and outdoor installations.

Item	Description	Qty.	Nominal Valve Size ANSI Inch (DN)			
			3 (DN80)	4 (DN100)	6 (DN150) <sup>e</sup>	8 (DN200)
			P/N	P/N	P/N	P/N
1	Valve Body	1	N/R	N/R	N/R	N/R
2	Diaphragm	1	545000030	545000040	545000060	545000080
3	Diaphragm Cover	1	N/R	N/R	N/R	N/R
4	Hex Bolt, Short	2 <sup>a</sup>	545100002	545100003	545100004	545100003
5	Hex Bolt, Long	2	545100012	545100013	545100014	545100015
6	Lift Washer	2 <sup>b</sup>	545100021	545100022	545100023	545100022
7	Hex Nut	2	545100032	545100033	545100034	545100033
8	Hoist Ring	2	545100041	545100041	545100041	545100041
9	Flat Washer	2	545100024	545100025	545100026	545100025

**NOTES**

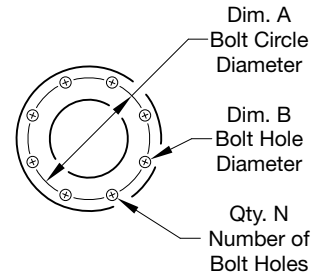
- a. Hex Bolt, Short, Qty. 6 in 6 and 8 inch (DN150 and DN200) assemblies.
- b. Lift Washer not used in 1-1/2 and 2 inch (DN40 and DN50) assemblies.
- c. N/R = Not Replaceable

- d. Order replacements parts only via Part Numbers given, do not replace Hex Bolt, Hex Nut, Lift Washer or Hoist Ring with common hardware parts.
- e. Also applicable to metric 165,1 mm size.



**FIGURE 1**  
**DV-5A VALVE ASSEMBLY AND REPLACEMENT PARTS**

Nominal Valve Size ANSI Inches (DN)	Flange Drilling Specification											
	Nominal Dimensions in Inches and (mm)											
	ANSI B16.42 <sup>a</sup> (Class 150)			ISO 7005-2 (PN16) <sup>b</sup>			JIS B 2210 (10K)			AS 2129 (Table F)		
	A	B	N	A	B	N	A	B	N	A	B	N
3 (80)	6.00 (152,4)	0.75 (19,0)	4	6.30 (160,0)	0.75 (19,0)	8	5.90 (150,0)	0.59 (15,0)	8	5.75 (146,0)	0.71 (18,0)	4
4 (100)	7.50 (190,5)	0.75 (19,0)	8	7.09 (180,0)	0.75 (19,0)	8	6.89 (175,0)	0.60 (15,0)	8	7.00 (178,0)	0.71 (18,0)	8
6 (150)	9.50 (241,3)	0.88 (22,2)	8	9.45 (240,0)	0.91 (23,0)	8	9.45 (240,0)	0.75 (19,0)	8	9.25 (235)	0.87 (22,0)	8
8 (200)	11.75 (298,5)	0.88 (22,2)	8	11.61 (295,0)	0.91 (23,0)	12	11.42 (290,0)	0.75 (19,0)	12	11.50 (292,0)	0.87 (22,0)	8



**NOTES**

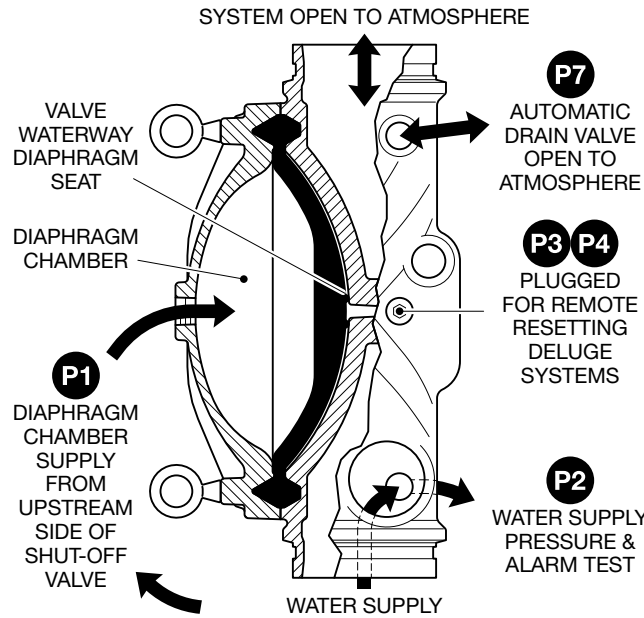
- a. Flat face flange; Same drilling as for ANSI B16.1 (Class 125)
- b. Same drilling as for BS 4504 Section 3.2 (PN16) and DIN 2532 (PN16)

**TABLE A**  
**FLANGE DRILLING SPECIFICATIONS**

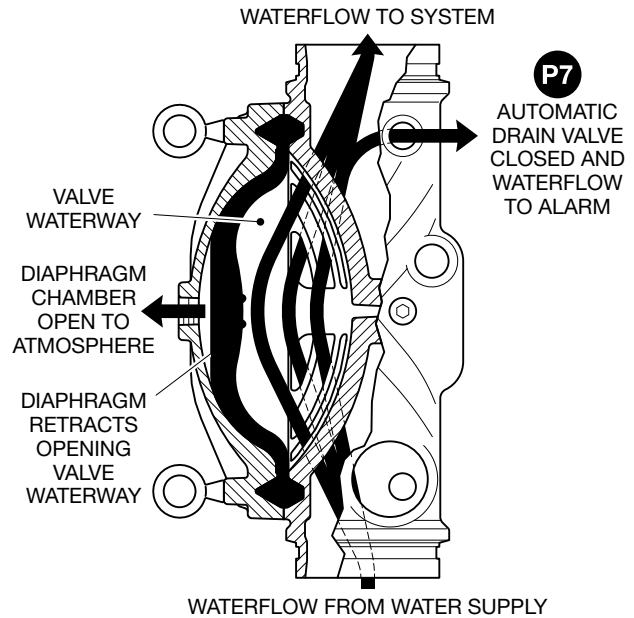
Port	Port Description	Port Sizes, NPT Inch per ANSI B1.20.1														
		3 (DN80)	4 (DN100)	6 (DN150) <sup>a</sup>	8 (DN200)											
P1	Diaphragm Chamber Supply	1/2	1/2	1/2	1/2											
P2	Water Supply Pressure & Alarm Test	1/2	1/2	1/2	1/2											
P3	Not Used	3/4	3/4	3/4	3/4											
P4	Not Used	1/2	1/2	1/2	1/2											
P5	System Drain	3/4	3/4	3/4 </tr <tr> <td>P6</td> <td>Main Drain</td> <td>1-1/4</td> <td>2</td> <td>2</td> <td>2</td> </tr> <tr> <td>P7</td> <td>Alarm Actuation</td> <td>1/2</td> <td>1/2</td> <td>1/2</td> <td>1/2</td> </tr>	P6	Main Drain	1-1/4	2	2	2	P7	Alarm Actuation	1/2	1/2	1/2	1/2
P6	Main Drain	1-1/4	2	2	2											
P7	Alarm Actuation	1/2	1/2	1/2	1/2											

**NOTES**

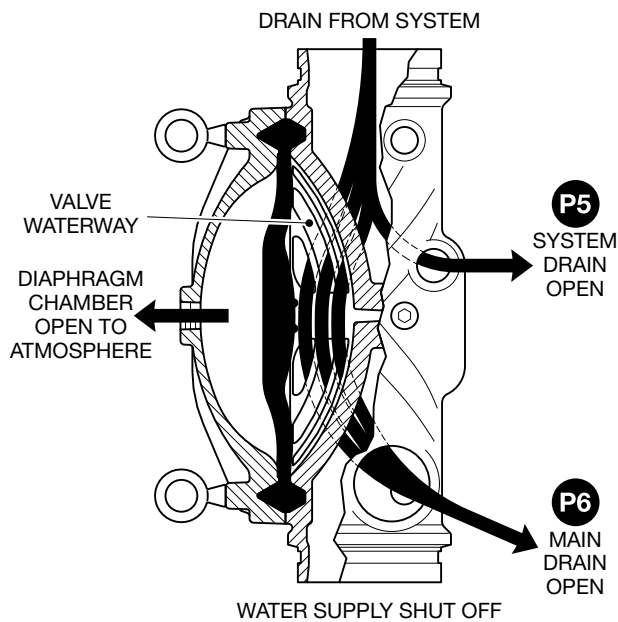
a. Also applicable to metric 165,1 mm size.



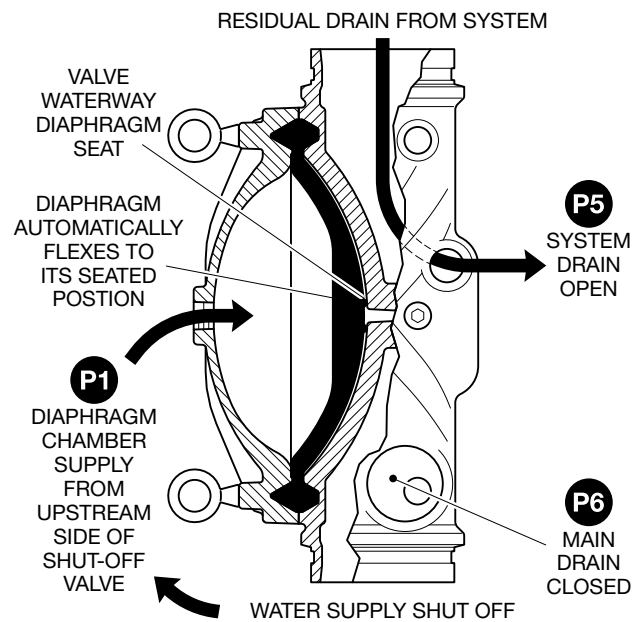
**FIGURE 2A**  
SET CONDITION



**FIGURE 2B**  
OPERATED CONDITION

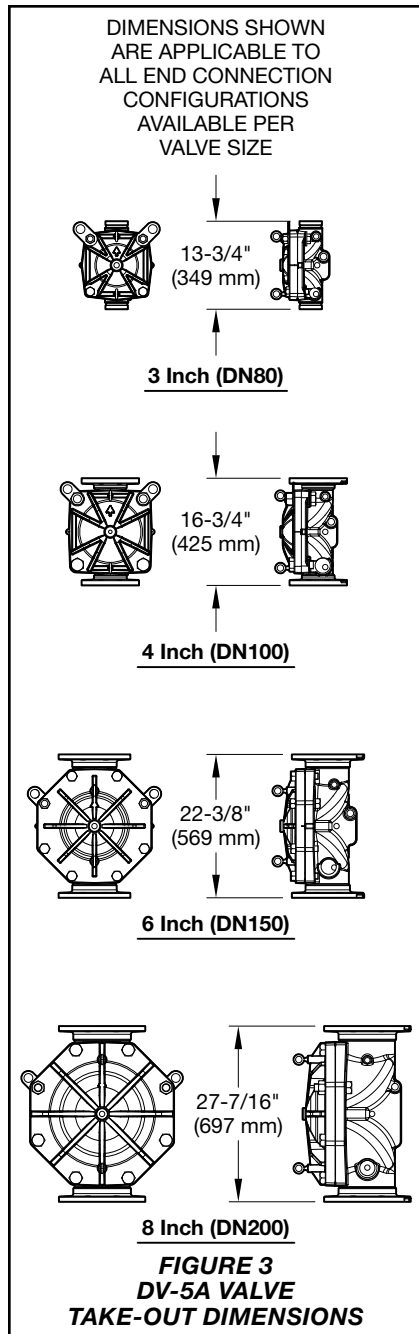


**FIGURE 2C**  
SYSTEM DRAIN CONDITION



**FIGURE 2D**  
RESIDUAL DRAIN CONDITION

**FIGURE 2**  
**DV-5A VALVE OPERATION, DELUGE REMOTE-RESETTING, PRESSURE-REDUCING SYSTEMS**



**NOTICE**

The DV-5A Valves described herein must be installed and maintained in compliance with this document, as well as with the applicable standards of the NATIONAL FIRE PROTECTION ASSOCIATION (NFPA), in addition to the standards of any other authorities having jurisdiction. Failure to do so may impair the performance of these devices.

The owner is responsible for maintaining their fire protection system and devices in proper operating condition. Contact the installing contractor or product manufacturer with any questions.

## Technical Data

### Approvals

UL and C-UL Listed  
LPCB Approved

Listings and Approvals are based on DV-5A Valves being trimmed as described in this technical data sheet and in conjunction with the use of the Burkert Type 5282 Solenoid.

For local EMEA regional approvals, consult with your local distributor.

### DV-5A Valve

Components for the 3 in. to 8 in. (DN80 to DN200) DV-5A Valves are shown in Figure 1. The DV-5A Valves are for vertical installations. They are rated for use at a service pressures of 20 to 300 psi (1,4 to 20,7 bar).

The take-out dimensions are shown in Figure 3, and flanged connections are available drilled per ANSI, ISO, AS, and JIS specifications (Ref. Table A). Threaded inlet and outlet connections are available in NPT or ISO 7/1. Threaded port connections are NPT threaded.

### Valve Trim

The maximum pressure rating is as follows:

- Deluge Remote-Resetting, Pressure-Reducing Trim is 250 psi (16 bar) dependent on separately ordered solenoid valve.

When the system pressure is greater than 175 psi (12,1 bar), provision is to be made to replace the standard order 300 psi (20,7 bar) Water Pressure Gauges with separately ordered 600 psi (41,4 bar) Water Pressure Gauges.

If the addition of an alarm control valve is desired or required by the local AHJ, the alarm control valve noted as Item H in Figure 9 is to be a separately ordered electronically supervised normally open valve.

External trim connections are NPT threaded. EMEA trim is provided with NPT x ISO 7/1 thread adapters.

### Pressure Loss

For the flow characteristics across the valve when the inlet pressure is below the set pressure, refer to Graph A through Graph D and Table B.

## Materials of Construction

### Valve Body

Epoxy coated ductile iron per ASTM A536-77, Grade 65-45-12

### Diaphragm Cover

Epoxy coated ductile iron per ASTM A536-77, Grade 65-45-12

### Diaphragm

Polyester fabric reinforced, TEFLON coated, EPDM rubber per ASTM D2000

### Diaphragm Cover Fasteners

Aluminum zinc coated steel

### Common Hardware Trim

- Common hardware pipe fittings are galvanized or black as required and are malleable per ASME B16.3.
- Common hardware pipe nipples are galvanized or black as required and are Schedule 40 per ASTM A53 or A135.
- Common hardware compression fittings are brass per ASTM B16.
- Common hardware tubing is Type L copper per ASTM B88.

## Design Criteria

The following items must be considered and applied accordingly for TYCO DV-5A Valve with Remote-Resetting, Pressure-Reducing Trim installations.

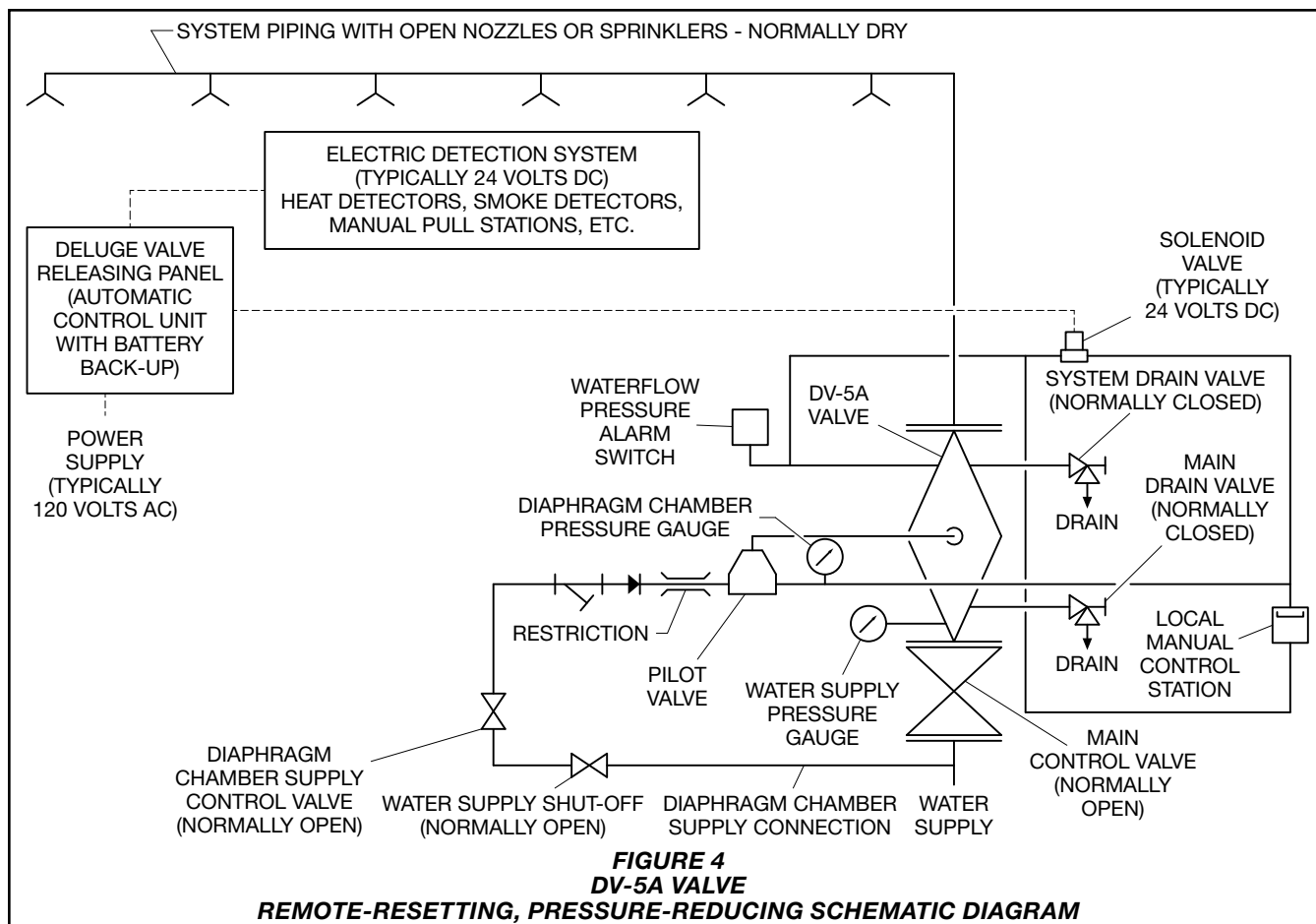
### NOTICE

The owner is responsible to design into the system a releasing circuit such that a Solenoid Valve is properly configured to enable remote resetting.

The building owner must be informed of the capabilities and limitations of a remote-resetting, pressure-reducing system as it pertains to the possibility of an inadvertent remote closing of the DV-5A valve during a fire condition. Therefore, personnel responsible for the fire protection system must be fully trained on system components and required actions in the case of an alarm.

The control panel, detectors, and pull stations are to be installed in accordance with their laboratory listings and approval.

System piping is to be installed so that it is self-draining. TYCO Model AD-2 Automatic Drain Valves can be used to drain low sections of pipe as necessary. For more information, refer to Technical Data Sheet TFP1632.



## Operation

The TYCO DV-5A Valve is a diaphragm style valve that depends upon water pressure in the diaphragm chamber (Ref. Figure 2A) to hold the diaphragm closed against the water supply pressure.

When the DV-5A valve with remote-resetting, pressure-reducing trim is set for service, the diaphragm chamber is pressurized through the trim connections from the inlet side of the system's main control valve.

With reference to Figure 4, initial activation of the solenoid valve due to electrical detection or activation of the electrical manual pull station results in the latched opening of the solenoid valve. Opening of the solenoid valve in the remote-resetting, pressure-reducing trim releases water from the diaphragm chamber faster than it can be replenished through the restriction in the diaphragm chamber supply connection provided in the trim. This release results in a rapid pressure drop in the diaphragm chamber, and the force differential applied through the diaphragm that holds it in the set position is reduced below the valve trip point.

The water supply pressure then forces the diaphragm open, permitting water to flow into the system piping, as well as through the alarm port to actuate system alarms.

To remotely reset the DV-5A valve, the voltage to the solenoid valve must be transferred to the appropriate terminals of the solenoid valve (Ref. Figure 5) resulting in the latched closure of the solenoid valve. Closing of the solenoid valve in the remote-resetting, pressure-reducing trim permits the diaphragm chamber to repressurize. This repressurizing results in a pressure increase in the diaphragm chamber. The resulting force repressurizes the diaphragm chamber, closing the valve and stopping the flow of water into the system piping.

## Installation

The TYCO DV-5A Valve is to be installed in accordance with this section.

### NOTICE

DV-5A Automatic Water Control Valves are designed to be used in freshwater systems. When the supply is from an alternative source such as brackish water, saltwater, or contains additives such as foam, the limited warranty is reduced to one year from the time of installation. An increase in frequency of inspections is required when the valve is exposed to such supplies and other corrosive conditions or chemicals that could impact valve materials or the operation of the assembly. The system and all components must be designed accordingly for the increased demand. It is required to thoroughly flush the valve and trim assembly with freshwater and reset to the set condition after each operation.

When installing the valve in a corrosive environment, including outdoor locations, protection from moisture, chemicals or fumes is highly recommended. Galvanic corrosion can result from joining unprotected dissimilar metals. For example, exposed steel pipe threads can become corroded if unprotected by painting or other coating methods. Where coating such exposed surfaces is impractical or unwanted, construct a rain-resistant roof or enclosure over the valve and trim.

Proper operation of the DV-5A valves depends upon their trim being installed in accordance with the instructions given in this technical data sheet. Failure to follow the appropriate trim diagram may prevent the DV-5A valve from functioning properly, as well as void approvals and the manufacturer's warranties.

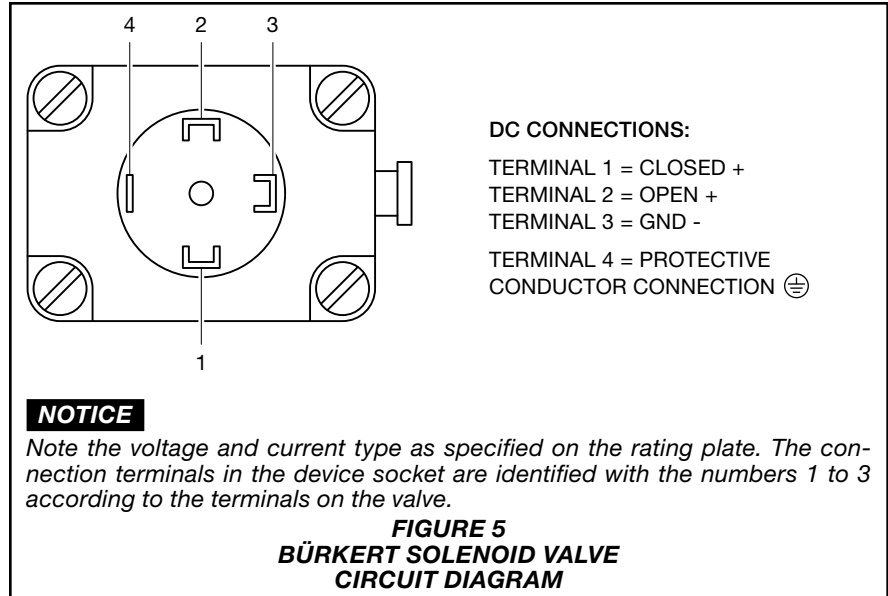
The DV-5A valve must be installed in a readily visible and accessible location.

The DV-5A valve and associated trim must be maintained at a minimum temperature of 40°F (4°C).

Heat tracing of the DV-5A valve or its associated trim is not permitted. Heat tracing can result in the formation of hardened mineral deposits that are capable of preventing proper operation.

Always open the system control valves slowly to avoid a sudden rush of water entering the system.

The DV-5A valve is to be installed in accordance with the following criteria:



**Step 1.** All nipples, fittings, and devices must be clean and free of scale and burrs before installation. Use pipe thread sealant sparingly on male pipe threads only.

**Step 2.** The DV-5A valve must be trimmed in accordance with Figure 6.

*Note: If the addition of an alarm control valve is desired or required by the local AHJ, the alarm control valve noted as Item H in Figure 9 is to be a separately ordered electronically supervised normally open valve.*

**Step 3.** Care must be taken to ensure that check valves, strainers, globe valves, etc. are installed with the flow arrows in the proper direction.

**Step 4.** Drain tubing to the drip funnel must be installed with smooth bends that will not restrict flow.

**Step 5.** The main drain and drip funnel drain may be interconnected provided a check valve is located at least 12 in. (300 mm) below the drip funnel.

**Step 6.** Suitable provision must be made for disposal of drain water. Drainage water must be directed such that it will not cause accidental damage to property or danger to persons.

**Step 7.** Connect the diaphragm supply Valve to the inlet side of the system main control valve in order to facilitate setting of the DV-5A valve. Refer to Figure 9.

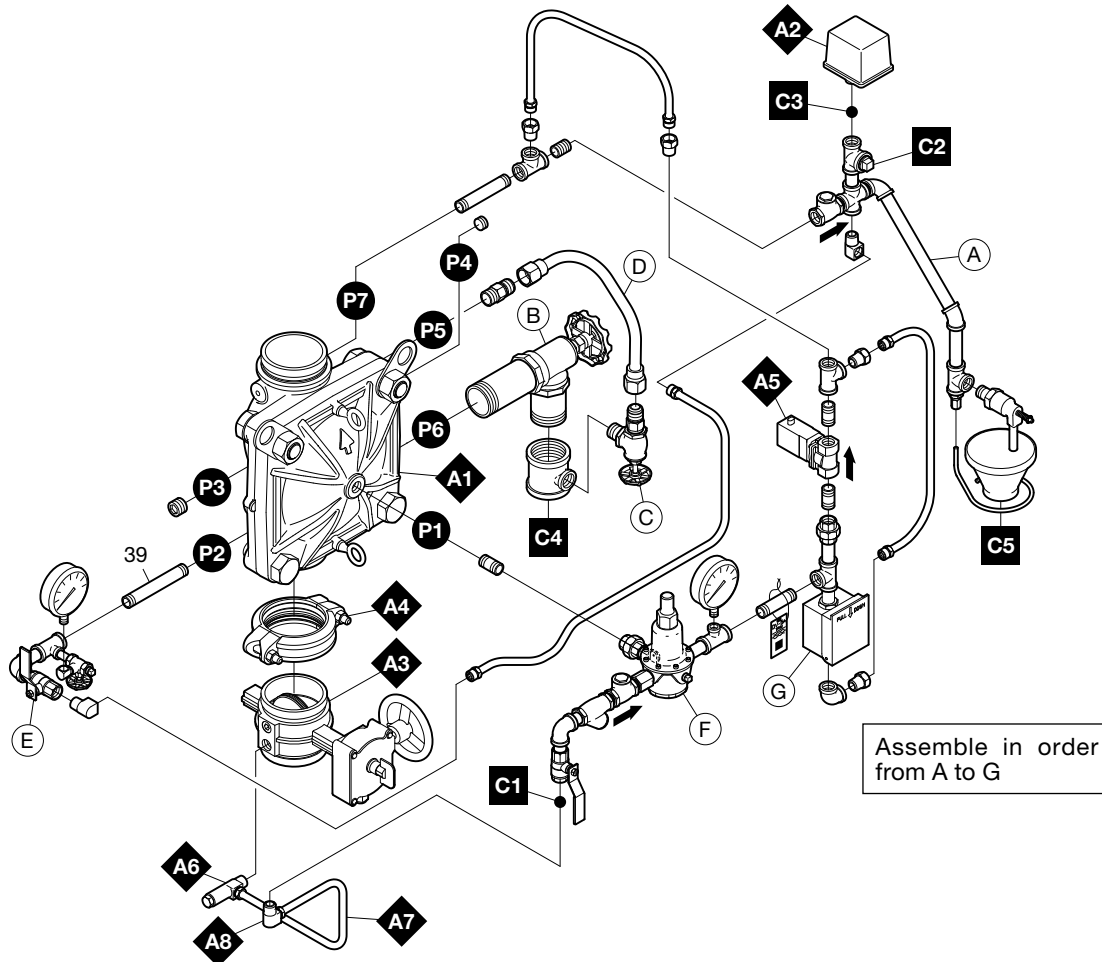
### NOTICE

*The connection to the Diaphragm Supply Valve should be as short as practical and from the same water supply as the system.*

**Step 8.** Unused pressure alarm switch connection must be plugged.

**Step 9.** Conduit and electrical connections are to be made in accordance with the applicable standards of the approval agency.

**Step 10.** Before a system hydrostatic test is performed, the DV-5A diaphragm chamber is to be depressurized, the automatic drain valve is to be temporarily replaced with a plug, and the diaphragm cover bolts must be uniformly and securely tightened using a cross-draw sequence. After tightening, double-check to make certain that all of the diaphragm cover bolts are securely tightened. Refer to Table C in the Care and Maintenance section for torque specifications.

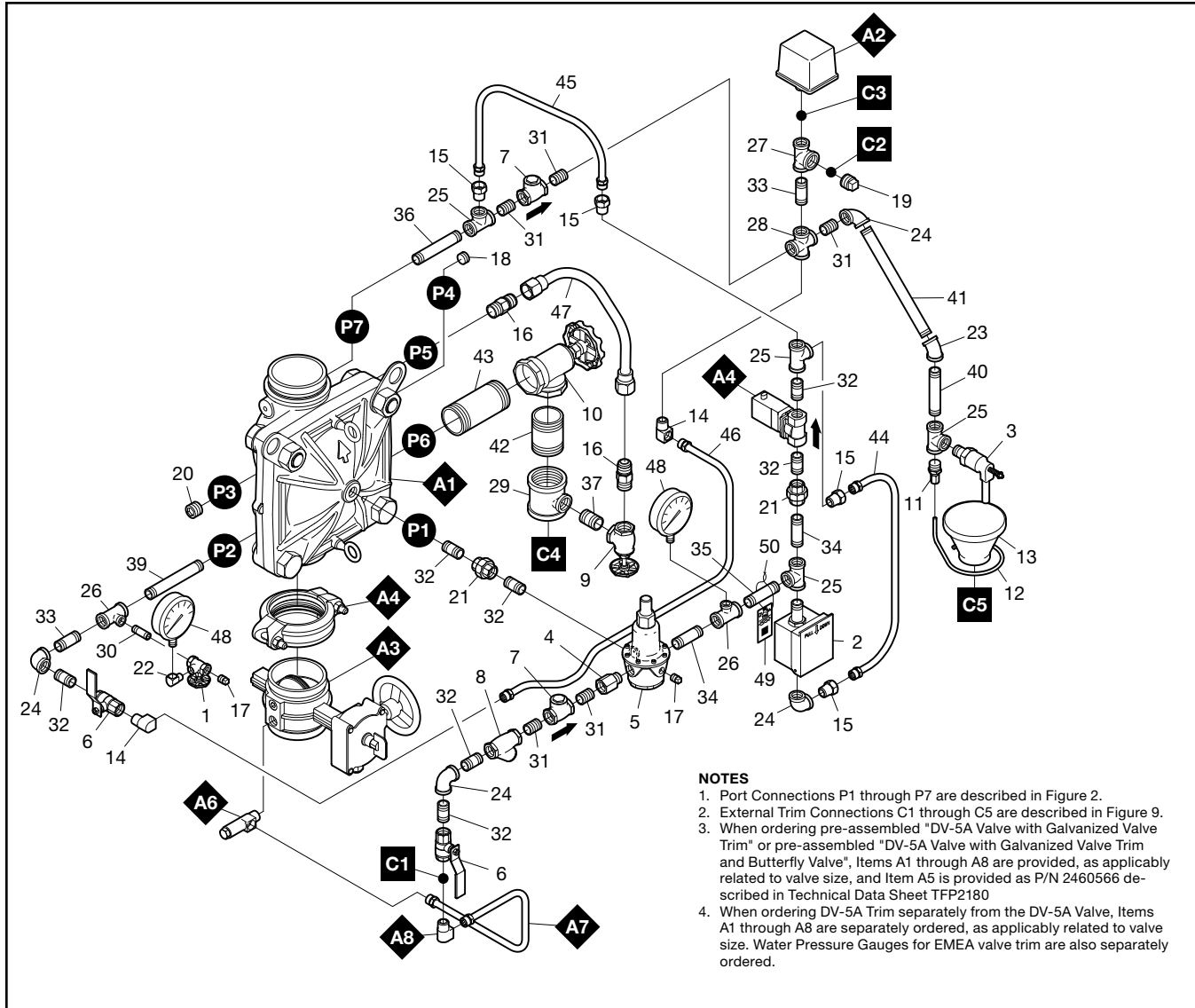


**NOTES**

1. Port Connections P1 through P7 are described in Figure 2.
2. External Trim Connections C1 through C5 are described in Figure 9.
3. When ordering pre-assembled "DV-5A Valve with Galvanized Valve Trim" or pre-assembled "DV-5A Valve with Galvanized Valve Trim and Butterfly Valve", Items A1 through A8 are provided, as applicably related to valve size, and Item A5 is provided as P/N 2460566 described in Technical Data Sheet TFP2180
4. When ordering DV-5A Trim separately from the DV-5A Valve, Items A1 through A8 are separately ordered, as applicably related to valve size. Water Pressure Gauges for EMEA valve trim are also separately ordered.

NIPPLE SELECTION PER VALVE SIZE				
NIPPLE	3 IN. (DN80)	4 IN. (DN100)	6 IN. (DN150)	8 IN. (DN200)
39	1/2" x 4-1/2"	1/2" x 5-1/2"	1/2" x 5-1/2"	1/2" x 6-3/4"

**FIGURE 6**  
**DV-5A VALVES – REMOTE-RESETTING, PRESSURE-REDUCING TRIM**  
**SEMI-ASSEMBLED**



- NOTES**
1. Port Connections P1 through P7 are described in Figure 2.
  2. External Trim Connections C1 through C5 are described in Figure 9.
  3. When ordering pre-assembled "DV-5A Valve with Galvanized Valve Trim" or pre-assembled "DV-5A Valve with Galvanized Valve Trim and Butterfly Valve", Items A1 through A8 are provided, as applicably related to valve size, and Item A5 is provided as P/N 2460566 described in Technical Data Sheet TFP2180
  4. When ordering DV-5A Trim separately from the DV-5A Valve, Items A1 through A8 are separately ordered, as applicably related to valve size. Water Pressure Gauges for EMEA valve trim are also separately ordered.

ITEM	QTY.	DESCRIPTION	CH	3 IN. (DN80)	4 IN. (DN100)	6 IN. (DN150) <sup>b</sup>	8 IN. (DN200)
1	1	1/4" GAUGE TEST VALVE		460051003	460051003	460051003	460051003
2	1	MC-2 MANUAL CONTROL STATION		545002000	545002000	545002000	545002000
3	1	AD-3 AUTOMATIC DRAIN VALVE		547932004	547932004	547932004	547932004
4	1	PRIMING SUPPLY RESTRICTION		545100051	545100051	1001514-04	1001514-06
5	1	PILOT VALVE		545100068	545100068	545100068	545100068
6	2	1/2" BALL VALVE		460501004	460501004	460501004	460501004
7	2	1/2" SWING CHECK VALVE		460491007	460491007	460491007	460491007
8	1	1/2" Y-STRAINER		523531006	523531006	523531006	523531006
9	1	3/4" ANGLE VALVE		460481010	460481010	460481010	460481010
10	1	ANGLE VALVE		460481011	460481012	460481012	460481012
11	1	DRIP FUNNEL BRACKET CONNECTOR		922111005	922111005	922111005	922111005
12	1	DRIP FUNNEL BRACKET		922111003	922111003	922111003	922111003
13	1	DRIP FUNNEL		923431007	923431007	923431007	923431007
14	2	FLARE FITTING 90° 1/2" NPT x 1/2" TUBE		545100062	545100062	545100062	545100062
15	4	FLARE FITTING 1/2" NPT x 1/2" TUBE		545100061	545100061	545100061	545100061
16	2	FLARE FITTING 3/4" NPT x 3/4" TUBE		545100063	545100063	545100063	545100063
17	2	PIPE PLUG	✓	1/4"	1/4"	1/4"	1/4"
18	1	SOCKET HEAD PIPE PLUG	✓	1/2"	1/2"	1/2"	1/2"
19	1	PIPE PLUG	✓	3/4"	3/4"	3/4"	3/4"
20	1	SOCKET HEAD PIPE PLUG	✓	3/4"	3/4"	3/4"	3/4"
21	2	UNION	✓	1/2"	1/2"	1/2"	1/2"

**FIGURE 7 (1 OF 2)**  
**DV-5A VALVES – REMOTE-RESETTING, PRESSURE-REDUCING TRIM**  
**EXPLODED VIEW**

ITEM	QTY.	DESCRIPTION	CH	3 IN. (DN80)	4 IN. (DN100)	6 IN. (DN150) <sup>b</sup>	8 IN. (DN200)
22	1	STREET ELBOW	✓	1/4" x 90°	1/4" x 90°	1/4" x 90°	1/4" x 90°
23	1	ELBOW	✓	1/2" x 45°	1/2" x 45°	1/2" x 45°	1/2" x 45°
24	4	ELBOW	✓	1/2" x 90°	1/2" x 90°	1/2" x 90°	1/2" x 90°
25	4	TEE	✓	1/2"	1/2"	1/2"	1/2"
26	2	REDUCING TEE	✓	1/2" x 1/2" x 1/4"	1/2" x 1/2" x 1/4"	1/2" x 1/2" x 1/4"	1/2" x 1/2" x 1/4"
27	1	REDUCING TEE	✓	1/2" x 1/2" x 3/4"	1/2" x 1/2" x 3/4"	1/2" x 1/2" x 3/4"	1/2" x 1/2" x 3/4"
28	1	REDUCING CROSS	✓	1/2"	1/2"	1/2"	1/2"
29	1	REDUCING TEE	✓	1-1/4" x 1-1/4" x 3/4"	2" x 2" x 3/4"	2" x 2" x 3/4"	2" x 2" x 3/4"
30	1	PIPE NIPPLE	✓	1/4" x 1-1/2"	1/4" x 1-1/2"	1/4" x 1-1/2"	1/4" x 1-1/2"
31	5	PIPE NIPPLE	✓	1/2" x CLOSE	1/2" x CLOSE	1/2" x CLOSE	1/2" x CLOSE
32	7	PIPE NIPPLE	✓	1/2" x 1-1/2"	1/2" x 1-1/2"	1/2" x 1-1/2"	1/2" x 1-1/2"
33	2	PIPE NIPPLE	✓	1/2" x 2"	1/2" x 2"	1/2" x 2"	1/2" x 2"
34	2	PIPE NIPPLE	✓	1/2" x 2-1/2"	1/2" x 2-1/2"	1/2" x 2-1/2"	1/2" x 2-1/2"
35	1	PIPE NIPPLE	✓	1/2" x 3"	1/2" x 3"	1/2" x 3"	1/2" x 3"
36	1	PIPE NIPPLE	✓	1/2" x 4-1/2"	1/2" x 4-1/2"	1/2" x 4-1/2"	1/2" x 4-1/2"
37	1	PIPE NIPPLE	✓	3/4" x 1-1/2"	3/4" x 1-1/2"	3/4" x 1-1/2"	3/4" x 1-1/2"
38	—	ITEM NOT USED		—	—	—	—
39	1	PIPE NIPPLE	✓	1/2" x 4-1/2"	1/2" x 5-1/2"	1/2" x 5-1/2"	1/2" x 6-3/4"
40	1	PIPE NIPPLE	✓	1/2" x 3-1/2"	1/2" x 4"	1/2" x 6-3/4"	1/2" x 6-3/4"
41	1	PIPE NIPPLE	✓	1/2" x 6-3/4"	1/2" x 9-1/2"	1/2" x 9-1/2"	1/2" x 9-1/2"
42	1	PIPE NIPPLE	✓	1-1/4" x 3-1/4"	2" x 3"	2" x 3"	2" x 3"
43	1	PIPE NIPPLE	✓	1-1/4" x 5-1/2"	2" x 5"	2" x 6"	2" x 8"
44	1	TUBING ASSY, MC-2 ACTUATION RELIEF		545100052	545100052	545100052	545100052
45	1	TUBING ASSY, SOLENOID ACTUATION RELIEF		545100037	545100038	545100039	545100040
46	1	TUBING ASSY, ALARM TEST INTERCONNECT		545100043	545100044	545100045	545100046
47	1	TUBING ASSY, SYSTEM DRAIN		535000430	535000440	535000460	535000480
48	2	WATER PRESSURE GAUGE, 300 PSI / 2000 kPa (AMER/APAC)		923431005	923431005	923431005	923431005
48	2	WATER PRESSURE GAUGE, 20 bar / 2000 kPa (EMEA)		025500013	025500013	025500013	025500013
49	1	LABEL		545003003	545003003	545003003	545003003
50	1	LABEL WIRE		545003003	545003003	545003003	545003003
A1	1	DV-5A VALVE, G x G		REFER TO TABLE F FOR DV-5a PART NUMBERS			
A2	1	WATERFLOW PRESSURE ALARM SWITCH, DOUBLE CONTACTS (APAC)		25710 or 100102	25710 or 100102	25710 or 100102	25710 or 100102
	1	WATERFLOW PRESSURE ALARM SWITCH, SINGLE CONTACTS (EMEA)		0260 or 100101	0260 or 100101	0260 or 100101	0260 or 100101
	1	WATERFLOW PRESSURE ALARM SWITCH, DOUBLE CONTACTS (AMER)		25710	25710	25710	25710
A3	1	BFV-300 BUTTERFLY VALVE, G x G		59300G030WS	59300G040WS	59300G060WS	59300G080WS
A4	1	FIGURE 577 RIGID GROOVED COUPLING		57730ACP	57740ACP	57760ACP	57780ACP
A5	1	SOLENOID VALVE		2460566	2460566	2460566	2460566
A6	1	INVERTED FLARE SHUT-OFF VALVE <sup>a</sup>		545100099	545100100	545100100	545100100
A7	1	TUBING ASSY, DIAPHRAGM CHAMBER SUPPLY		545100053	545100055	545100056	545100057
A8	1	FLARE FITTING 90° 1/2" NPT x 1/2" TUBE		545100062	545100062	545100062	545100062

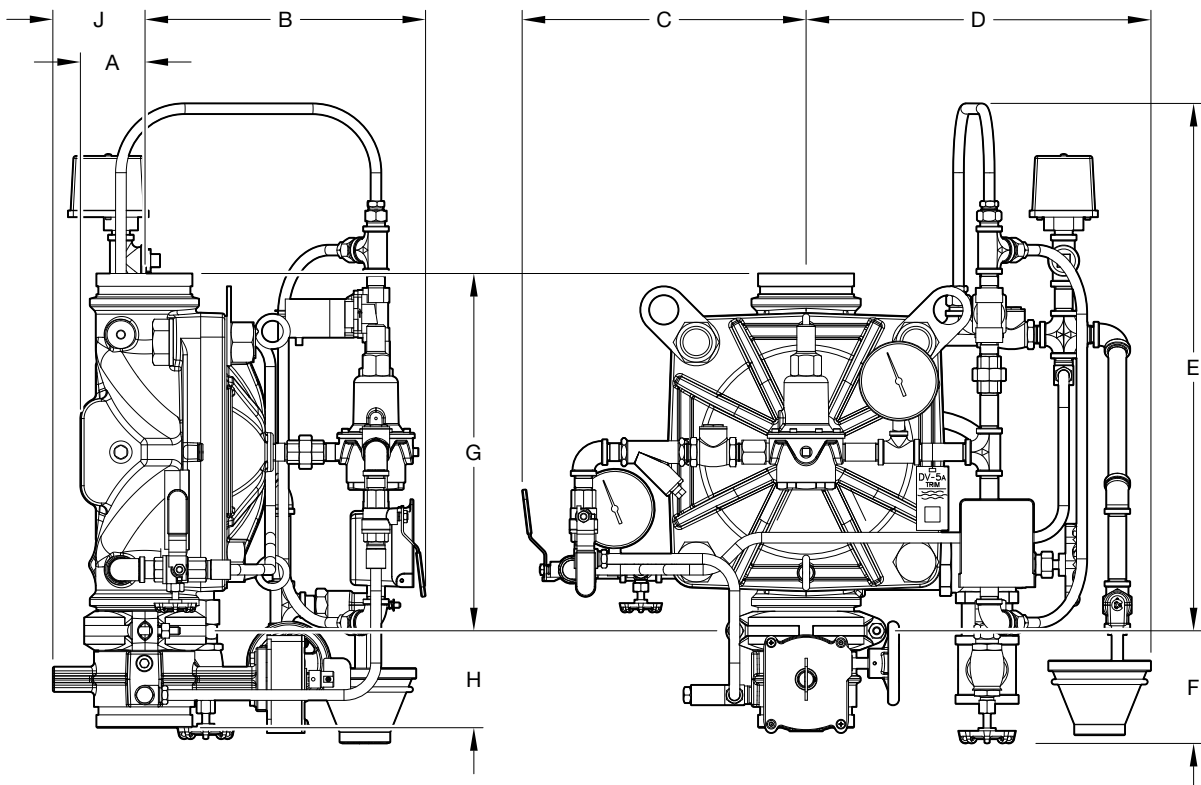
**NOTES**

- a. Not VdS Approved
- b. Also applicable to metric 165,1 mm size.
- CH - Common Hardware - Refer to Materials of Construction section for specifications.

**FIGURE 7 (2 OF 2)**  
**DV-5A VALVES – REMOTE-RESETTING, PRESSURE-REDUCING TRIM**  
**EXPLODED VIEW**

Nominal Valve Size ANSI Inches (DN)	Inches (mm)								
	A	B	C	D	E	F	G	H	J
3 (80)	4.0 (102)	11.0 (279)	11.5 (292)	16.0 (406)	22.4 (569)	6.0 (152)	13.8 (351)	3.79 (96)	3.6 (91)
4 (100)	4.5 (114)	12.7 (323)	12.6 (320)	16.1 (409)	24.0 (584)	5.1 (130)	16.8 (427)	4.54 (115)	4.3 (109)
6 <sup>3</sup> (150)	5.7 (145)	13.5 (343)	14.5 (368)	18.0 (457)	26.8 (681)	4.1 (104)	22.4 (569)	5.83 (148)	5.7 (145)
8 (200)	6.8 (174)	16.2 (412)	16.7 (424)	19.0 (483)	30.3 (770)	2.9 (74)	27.5 (699)	5.24 (133)	6.7 (170)

**NOTES**  
 1. Dimensions based on drain valves being open  
 2. Dimensions do not provide installation clearance  
 3. Also applicable to metric 165,1 mm size.



**FIGURE 8**  
**DV-5A VALVE – REMOTE-RESETTING, PRESSURE-REDUCING TRIM**  
**NOMINAL DIMENSIONS**

## Valve Setting Procedure

Perform Steps 1 through 13 when initially setting the TYCO DV-5A Valve with Remote-Resetting, Pressure-Reducing Trim for service or after an operational test of the fire protection system (Ref. Figure 9).

**Step 1.** Close the system main control valve (B).

**Step 2.** Close the diaphragm supply valve (P).

**Step 3.** Open the main drain valve (D) and system drain valve (E). Close the system drain valve (E) after water ceases to discharge. Leave the main drain valve (D) open.

At this time make certain that the pressure gauge valves and the alarm control valve (H), as applicable, are open.

**Step 4.** Depress the plunger of the automatic drain valve (F) to verify that it is open.

**Step 5.** Clean the diaphragm supply strainer (Q) by removing the clean-out plug and strainer basket. The diaphragm supply strainer (Q) may be flushed out by momentarily opening the diaphragm supply valve (P).

**Step 6.** Reset the electric detection system in accordance with the manufacturer's instructions to de-energize the solenoid valve.

**Step 7.** Operate (open) the manual control station (M) and then open the diaphragm supply valve (P). After un-aerated water ceases to discharge from the manual control station (M) drain tube, slowly close the operating lever by pushing it up. Do not close the hinged cover at this time.

**Step 8.** Inspect drain connections from the manual control station and solenoid valve. Before proceeding to the next step, correct any leaks.

**Step 9.** Verify the ability for the DV-5A diaphragm to hold pressure as follows:

- With the diaphragm chamber pressurized per Step 7, temporarily close the diaphragm supply valve (P), and then observe the diaphragm gauge (K) for a drop in pressure.
- If a drop in pressure is noted, the DV-5A diaphragm is to be replaced and/or any leaks must be corrected before proceeding to the next step.
- If the diaphragm gauge (K) indicates no drop in pressure, re-open the diaphragm supply valve (P) and proceed to the next step.

**Step 10.** Partially open the system main control valve (B). Slowly close the main drain valve (D) as soon as water discharges from the main drain valve (D). Observe the automatic drain valve (F) for leaks. If there are leaks, determine/correct the cause of the leakage problem before proceeding.

### NOTICE

*When the system main control valve (B) is partially opened, the pressure on the DV-5A diaphragm chamber may increase. This increase in pressure is normal, and if the pressure is greater than the valve trim maximum pressure rating provided in the Technical Data section, the pressure is to be relieved to at least the valve trim pressure rating by partially and temporarily opening the manual control station (M); however, do not allow the pressure as indicated on the diaphragm gauge (K) to drop below the supply pressure shown on the water supply gauge (J), since this action may result in tripping of the DV-5A valve.*

**Step 11.** Close the hinged cover of the manual control station valve (M) and insert a new break rod in the small hole through the top of the enclosing box.

**Step 12.** Fully open the system main control valve (B).

**Step 13.** After setting a fire protection system, notify the proper authorities and advise those responsible for monitoring proprietary and/or central station alarms.

## Adjusting Pilot Valve Pressure

A minimum flow of 100 gpm (380 lpm) is required to adjust the Pilot Valve's pressure.

### NOTICE

*After any downstream pressure adjustment, the following items are to be recorded on a tag attached to the valve:*

- Valve installation location
- Inlet static pressure
- Inlet residual pressure
- Outlet residual pressure
- Intended outlet flow

*The tag is not to be removed until after the system has been accepted by the authority having jurisdiction. It is recommended that the tag not be removed even after acceptance by the authority having jurisdiction unless another*

*means of record keeping is maintained.*

Pressure in the pilot valve is factory-set. To re-adjust the pressure, set the valve first, according to the Valve Setting Procedure described in this technical data sheet, then follow the steps below. Refer to Figure 10 as needed.

**Step 1.** To set the pressure in the field, trip the valve manually or electrically. It is recommended that the valve is tripped electrically to test the entire system.

**Step 2.** Remove the tamper cap of the pilot valve by first loosening the set screw and unscrewing the tamper cap.

**Step 3.** If surging flow occurs, attempt to bleed trapped air from the system via the automatic drain valve.

**Step 4.** Loosen the lock nut on the adjusting screw of the pilot valve.

**Step 5.** Turn the adjusting screw clockwise to increase outlet pressure or counterclockwise to decrease outlet pressure.

**Step 6.** Observe the outlet pressure gauge for changes. The valve needs time to reach the new set point after changing the preset pressure. Turn the adjusting screw ½ turn at a time until the pressure stabilizes.

If necessary, turn the adjusting screw again until the desired set point is achieved.

**Step 7.** After the desired performance, tighten the lock nut.

**Step 8.** Replace the tamper cap and tighten the set screw.

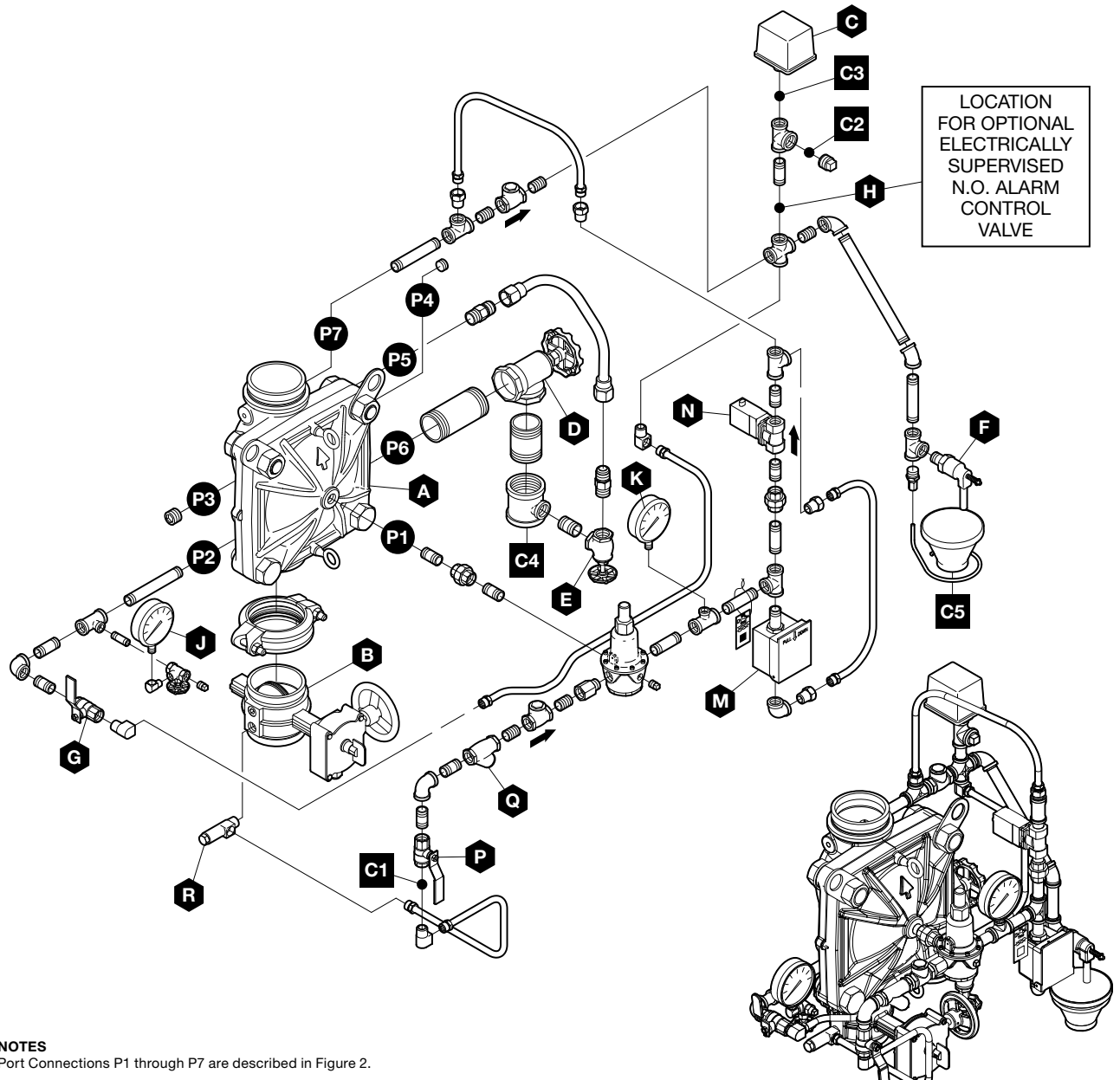
**Step 9.** Ensure that the system is properly drained.

The DV-5A Deluge Valve is now set for service.

Item	Description
A	DV-5A Valve
B	System Main Control Valve
C	Waterflow Pressure Switch
D	Main Drain Valve
E	System Drain Valve
F	Automatic Drain Valve
G	Alarm Test Valve
H	Alarm Control Valve (Optional)

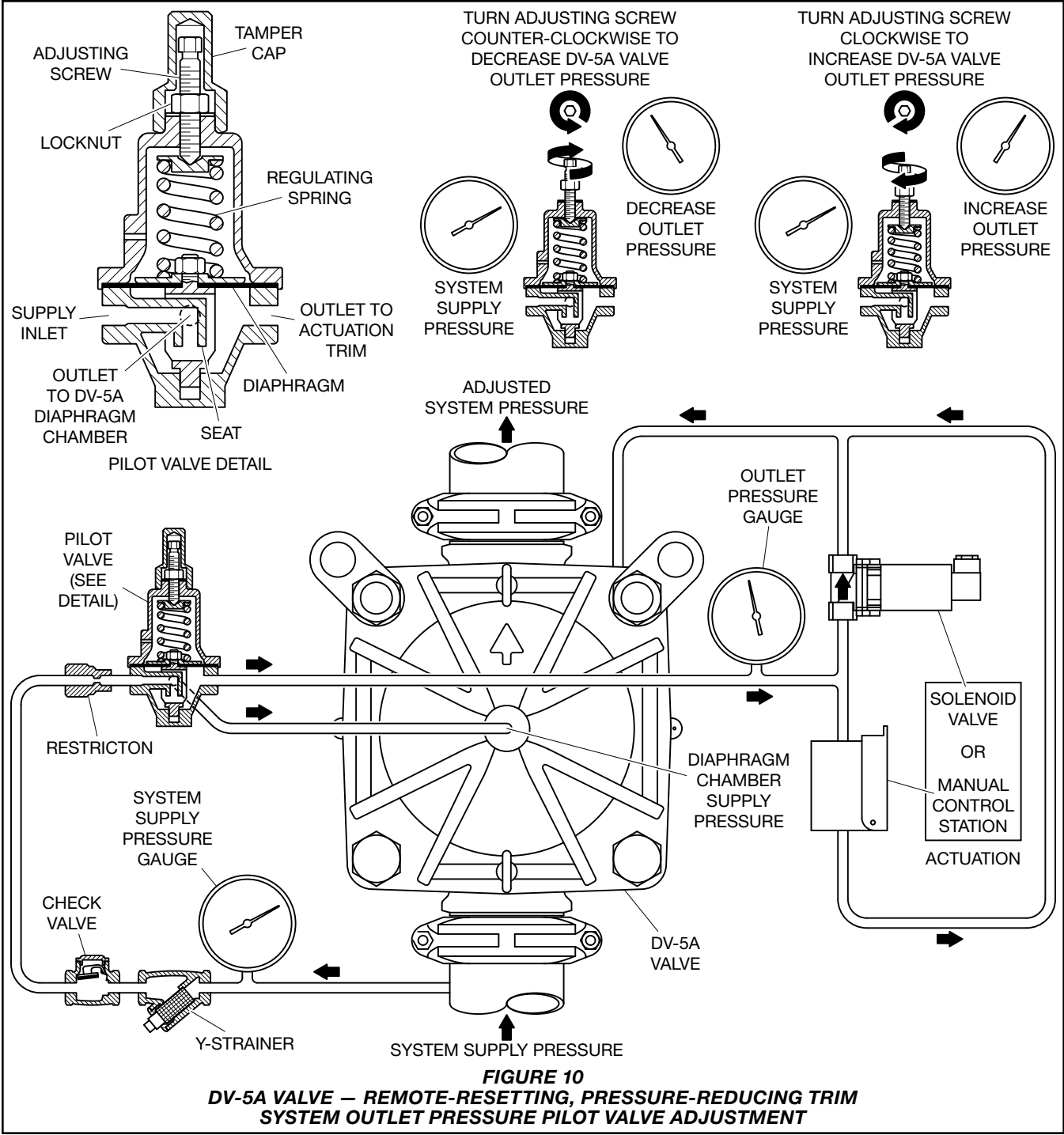
Item	Description
J	Water Supply Gauge
K	Diaphragm Gauge
L	(Not Used)
M	Manual Control Station
N	Solenoid Valve
P	Diaphragm Supply Valve
Q	Diaphragm Supply Strainer
R	Inverted Flare Shut-Off Valve

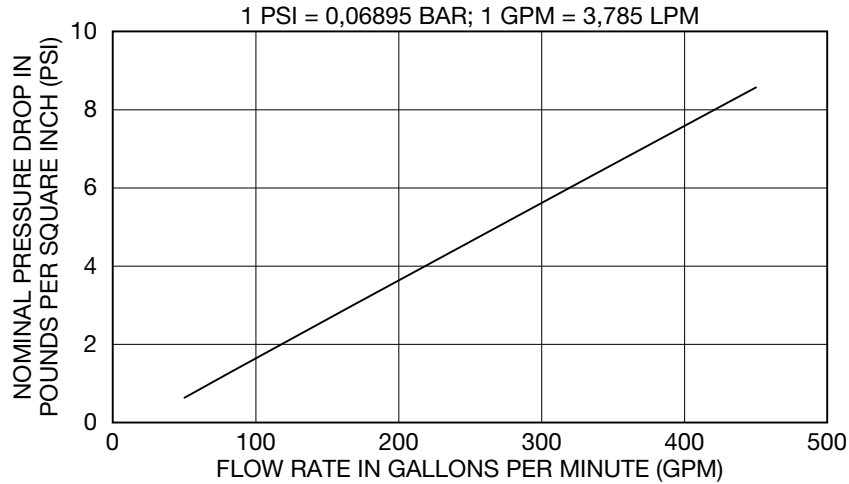
External Trim Connections	
C1	Diaphragm Supply Connection
C2	Water Motor Alarm Connection
C3	Waterflow Pressure Alarm
C4	Switch Connection
C5	Main Drain Connection Drip Funnel Drain Connection



**NOTES**  
 Port Connections P1 through P7 are described in Figure 2.

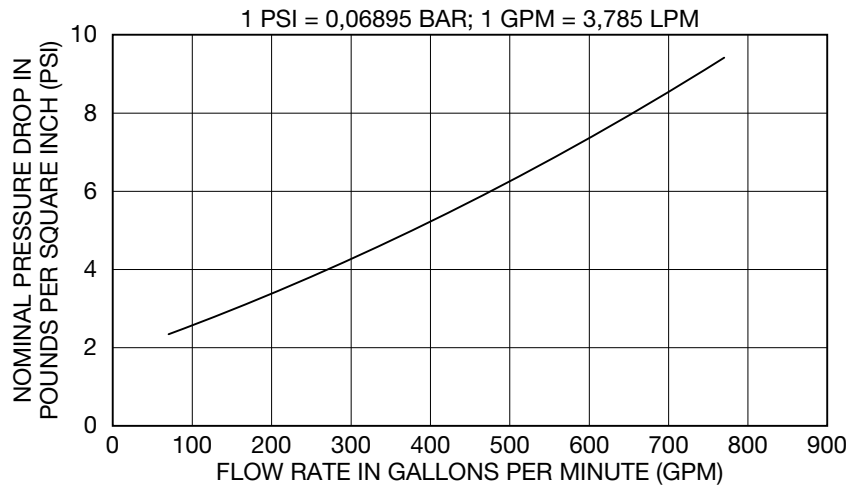
**FIGURE 9**  
**DV-5A VALVE – REMOTE-RESETTING, PRESSURE-REDUCING TRIM**  
**(REFER TO FIGURE 6 FOR SPECIFIC BILLS OF MATERIALS)**





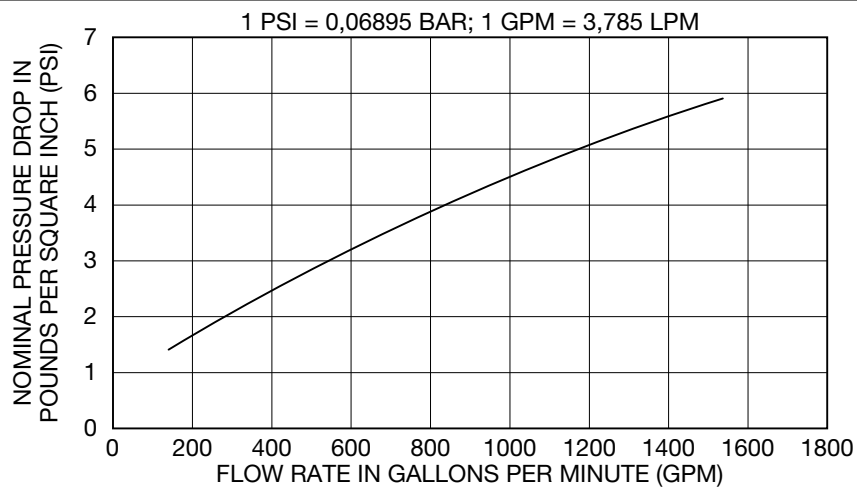
**Note:**  
 When inlet pressure falls below set pressure.

**GRAPH A**  
**3 INCH (DN80) DV-5A DELUGE VALVE WITH REMOTE-RESETTING, PRESSURE-REDUCING TRIM**  
**MINIMUM PRESSURE DROP**



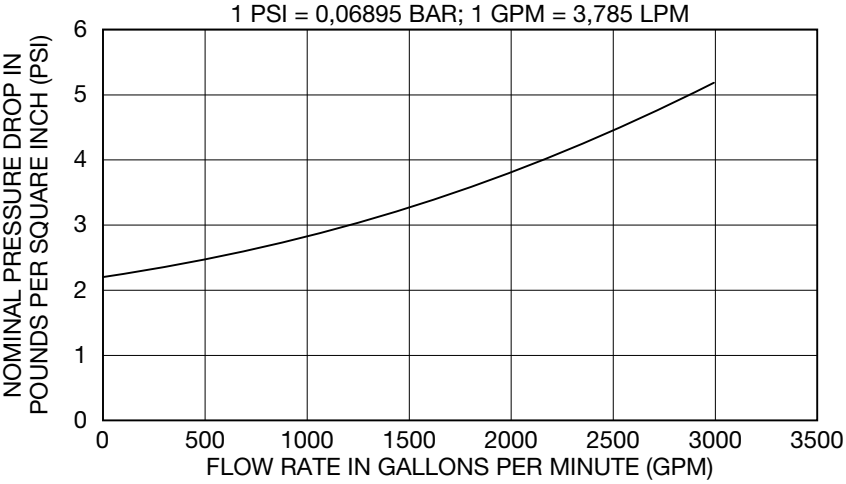
**Note:**  
 When inlet pressure falls below set pressure.

**GRAPH B**  
**4 INCH (DN100) DV-5A DELUGE VALVE WITH REMOTE-RESETTING, PRESSURE-REDUCING TRIM**  
**MINIMUM PRESSURE DROP**



**Note:**  
 When inlet pressure falls below set pressure.

**GRAPH C**  
**6 INCH (DN150) / 165,1 MM DV-5A DELUGE VALVE WITH REMOTE-RESETTING,**  
**PRESSURE-REDUCING TRIM MINIMUM PRESSURE DROP**



**Note:**  
 When inlet pressure falls below set pressure.

**GRAPH D**  
**8 INCH (DN200) DV-5A DELUGE VALVE WITH REMOTE-RESETTING, PRESSURE-REDUCING TRIM**  
**MINIMUM PRESSURE DROP**

Nominal Valve Size ANSI Inches (DN)	Max Rated Inlet Pressure psig (bar)	Outlet Pressure Setting Range psig (bar)
3 (80)	250 (16,0)	90 - 175 (6,2 - 12,1)
4 (100)	250 (16,0)	80 - 175 (5,5 - 12,1)
6' (150)	250 (16,0)	90 - 175 (6,2 - 12,1)
8 (200)	250 (16,0)	80 - 175 (5,5 - 12,1)

**NOTES**  
 1. Also applicable to metric 165,1 mm size

**TABLE B**  
**DV-5A DELUGE VALVE WITH REMOTE-RESETTING,**  
**PRESSURE-REDUCING TRIM**  
**MAXIMUM INLET PRESSURE AND OUTLET SETTING RANGE**

## Care and Maintenance

The following procedures and inspections must be performed as indicated, in addition to any specific requirements of the NFPA and any applicable standards recognized by the Approval agency. Any impairment must be immediately corrected (Ref. Figure 9).

### NOTICE

*If the water supply needs to be shut off to the DV-5A valve and trim and cannot be shut off upstream of the system, close the system main control valve (B), the diaphragm supply valve (P), and the water supply shut-off valve (R). This will allow any trim above the system main control valve (B) to be taken apart for service if necessary.*

*The frequency at which the following procedures and inspections are to be performed are to be in accordance with the NFPA and any applicable specific requirements of the standards recognized by the Approval agency.*

*Before closing a fire protection system main control valve for maintenance work on the fire protection system that it controls, permission to shut down the affected fire protection systems must first be obtained from the proper authorities and all personnel who may be affected by this action must be notified.*

*The owner is responsible for the inspection, testing, and maintenance of their fire protection system and devices in compliance with this document, as well as with the NFPA and any applicable standards recognized by the Approval agency. Contact the installing contractor or product manufacturer with any questions.*

*Some procedures in this section result in the operation of the associated alarms. Notify the owner and the fire department, central station, or other signal station to which the alarms are connected before performing the tests.*

*It is recommended that automatic sprinkler systems be inspected, tested, and maintained by a qualified Inspection Service in accordance with the NFPA and any applicable standards recognized by the Approval agency.*

### Drop in Water Supply Pressure Below Normal Range

#### NOTICE

*If the water supply pressure is significantly reduced below the normally expected static pressure range (as could occur in the case of a water main break or repair), and there is a subsequent drop in the diaphragm chamber water pressure below its normal range (for example, due to a leak in a piping connection to or from the diaphragm chamber or, a leak in the diaphragm chamber check valve caused by dirt or debris in the check valve seal area), a deluge valve such as the DV-5A valve could inadvertently trip, if its water supply pressure is quickly restored.*

A drop in the water supply pressure to below its normal range (as in the case of an interrupted water supply condition) constitutes an emergency impairment.

Should this condition occur, immediately close the main control valve and use the following procedure to reset the system:

**Step 1.** Prior to the water supply pressure being restored to the closed main control valve, note the pressure indicated by the diaphragm chamber pressure gauge and determine if the pressure is within the normally expected range.

**Step 2.** If the diaphragm chamber pressure is below the normal range, check for and correct any source of leakage from the diaphragm chamber prior to resetting the system.

**Step 3.** After the water supply pressure is restored to the main control valve, reset the DV-5A valve in accordance with the Valve Setting Procedure section.

#### NOTICE

*For fire protection systems subject to an emergency impairment caused by an interrupted water supply condition, it is recommended that consideration be given to installing a low water supply pressure switch with the appropriate alarm/indications to monitor the water supply pressure.*

### Waterflow Alarm Test Procedure

To test the waterflow alarm, open the alarm test valve (G), which will allow a flow of water to the waterflow pressure switch (C) and/or water motor alarm. Upon satisfactory completion of the test, close the alarm test valve (G).

To ensure drainage of the alarm line, depress the plunger on the automatic drain valve (F).

### Electric Actuation

#### Operation Test Procedure

Proper operation of the DV-5A valve (i.e., opening of the DV-5A valve as during a fire condition) must be verified as follows:

**Step 1.** If water must be prevented from flowing beyond the riser, perform the following steps.

- Close system main control valve (B). Open main drain valve (D).
- Open system main control valve (B) one turn beyond position at which water just begins to flow from main drain valve (D).
- Slowly close the main drain valve (D).

**Step 2.** Test the deluge releasing panel in accordance with the manufacturer's instructions to energize the solenoid valve.

*Note: Be prepared to quickly perform Steps 3, 4, and 5 if water must be prevented from flowing beyond the riser.*

**Step 3.** Verify that the DV-5A valve has tripped, as indicated by the flow of water into the system.

**Step 4.** Close the system main control valve (B).

**Step 5.** Close the diaphragm supply valve (P).

**Step 6.** Reset the DV-5A valve in accordance with the Valve Setting Procedure.

### Electric Actuation

#### Solenoid Valve (N) Test Procedure

Proper operation of the solenoid valve (N) for electric actuation must be verified as follows:

**Step 1.** Close the system main control valve (B).

**Step 2.** Open the main drain valve (D).

**Step 3.** Test the deluge releasing panel in accordance with the manufacturer's instructions to energize the solenoid valve (N).

**Step 4.** Verify that there is a flow of water from the solenoid valve (N) drain connection.

**Step 5.** Verify that the diaphragm chamber pressure has decreased to below 25% of the water supply pressure.

**Step 6.** Reset the electric detection system in accordance with the manufacturer's instructions to de-energize the solenoid valve (N), and proceed as follows:

- Water should cease draining from the solenoid valve (N).
- Pressure will then build up in the DV-5A diaphragm chamber.
- After system pressure is restored in the DV-5A diaphragm chamber, inspect the solenoid valve (N) for leaks at the drain tube. Any leaks must be corrected before proceeding to the next step. The solenoid valve (N) discharges water into the riser and must be drained at the conclusion of this test.

**Step 7.** Partially open the system main control valve (B). Slowly close the main drain valve (D) as soon as water discharges from the main drain valve (D). Observe the automatic drain valve (F) for leaks. If there are leaks, determine/correct the cause of the leakage problem. If there are no leaks, the DV-5A valve is ready to be placed in service and the system main control valve (B) must then be fully opened.

**Internal Valve Inspection**

Once every five years during the annual operational test procedure and prior to the DV-5A valve being reset and with the DV-5A valve de-pressurized, the interior of the DV-5A valve must be cleaned and inspected for wear and damage. Damaged or worn parts must be replaced. (Replacement of the diaphragm every ten years is recommended, or more frequently if inspections and/or wear and tear warrant more frequent replacement.)

**NOTICE**

*The diaphragm cover may be removed between Steps 4 and 5 of the resetting instructions, since at that point the DV-5A valve should be de-pressurized as evident by a zero gauge reading on the diaphragm gauge (K) and water supply gauge (J), as well as no water discharging from the automatic drain valve (F).*

*Ensure that the diaphragm supply valve (P) and the system main control valve (B) are closed before removing the cover.*

To perform internal valve inspection between Steps 4 and 5 of the Valve Setting Procedure, remove the diaphragm cover as follows:

**Step 1.** Close the inverted flare shut-off valve (R).

**Step 2.** Remove the copper tube fitting between the diaphragm supply valve (P) and the inverted flare shut-off valve (R).

**Step 3.** Loosen the union securing the solenoid valve (N).

**Step 4.** Loosen and remove the union between the diaphragm cover and the trim and remove the trim.

**Step 5.** Remove the diaphragm valve cover hardware, then slowly remove the diaphragm cover and perform internal valve inspection. Clean the valve interior and replace parts as necessary.

After cleaning and inspecting valve interior, and replacing parts as necessary, reinstall the diaphragm cover by completing the following steps to assure the diaphragm cover fasteners are uniformly and securely tightened.

**Step 1.** With reference to Figure 1, ensure that the diaphragm is properly oriented and that the proper hardware arrangement is utilized when assembling the diaphragm covers. The hardware arrangements differ depending on the size of the DV-5A valve.

**Step 2.** By first using the long hex bolts, support of the diaphragm cover will be provided before installing the short hex bolts. Align diaphragm in proper orientation with valve body, and then align diaphragm cover in proper orientation with valve body. Hand-tighten all fasteners.

**Step 3.** Using crossdraw sequence to assure uniformity, wrench-tighten long hex bolts and short hex bolts to appropriate torque values. Repeat crossdraw sequence two to three times at incremental torque values until reaching the torque values found in Table C.

**Step 4.** Inspect to assure all hex bolts are securely tightened.

**Step 5.** Using the union, the trim to the diaphragm cover.

**Step 6.** Using the union, secure the solenoid valve (N).

**Step 7.** Replace the copper tube fitting between the diaphragm supply valve (P) and the inverted flare shut-off valve (R).

**Step 8.** Ensure that the unions and flare fittings are securely tightened.

Nominal Valve Sizes ANSI Inches (DN)	Torque lb-ft (N-m)	
	Nuts	Short Hex Bolts
3 (80)	125 (169,5)	125 (169,5)
4 (100)	150 (203,4)	150 (203,4)
6 <sup>1</sup> (150)	150 (203,4)	150 (203,4)
8 (200)	188 (254,9)	188 (254,9)

**NOTES**  
1. Also applicable to metric 165,1 mm size.

**TABLE C  
DIAPHRAGM COVER BOLTS  
MINIMUM TORQUE**

**Step 9.** With the diaphragm supply valve (P) closed, fully open the inverted flare shut-off valve (R) stainless steel screw (approximately 1/2 in.) until resistance is met so as not to break the internal roll-pin. The internal roll-pin stops the removal of the inverted flare shut-off valve (R) stainless steel screw.

**Step 10.** Proceed to step 5 of the Valve Setting Procedures section in this data sheet.

**NOTICE**

*If the water supply contains chemicals which tend to attack a polyester fabric-reinforced, EPDM rubber or the five year inspection indicates a build-up of debris within the DV-5A valve that could affect its proper operation, then the frequency of the internal valve inspection procedure must be appropriately increased.*

*With reference to Figure 1, make certain that the diaphragm is correctly oriented; otherwise, the DV-5A valve cannot be properly set.*

*Under-tightening the diaphragm cover bolts can result in internal and external leakage.*

*Use only TYCO replacement fasteners as specified in Figure 1.*

*Do not apply adhesives, lubricants, or other substances to the diaphragm or valve body.*